

bravo[®]

lever hoists 500 to 6000 kg

for lifting,
pulling tensioning...



 **Tractel** Group

bravo®

Range of lever hoists lightweight, compact, powerful and easy to operate.

Quality products guaranteed by the TRACTEL Group, the range of BRAVO lever hoists is manufactured from high quality materials giving a strong and robust unit for operating even in the most difficult conditions. All the product features make the BRAVO safe and easy to operate :

- ◆ free-wheel safety device activates a braking mechanism securely holding the load when the hoist is in the neutral position.

- ◆ chain wind-through for fast positioning of the hook.
- ◆ ISO grade 80 (DIN 5684 grade 8 and NF E 26-010) link load chain.
- ◆ lightweight and portable with simple straightforward controls.
- ◆ wide opening swivel hooks with safety catches.
- ◆ low effort for maximum lift.

CE marked (machine Directive 89/392/CEE, amended by 91/368/CEE, 93/44/CEE and 93/68/CEE).

The 5 models of the BRAVO from 500 to 6000 kg are suitable for a wide variety of lifting, pulling and tensioning applications: for lifting and lowering loads in factories and garages, for removing engines and handling machinery, loading and unloading vehicles, applying tension to conveyor belts or chains, and a host of other applications.

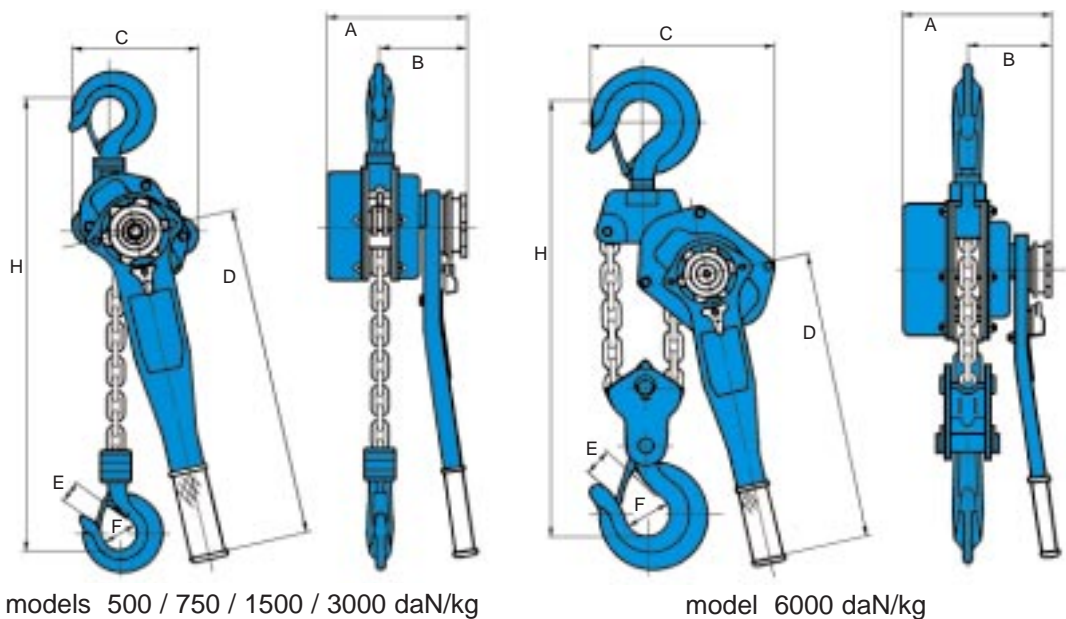

Specification	Unit	Capacity of models BRAVO				
		500	750	1500	3000	6000
Capacity	daN/kg	500	750	1500	3000	6000
Standard lift*	m	1.50	1.50	1.50	1.50	1.50
Number of falls of chain		1	1	1	1	2
Effort to lift maximum load	daN/kg	40	20	22	40	32
Weight (standard* equipment)	kg	5	7	11	20	30
Chain dimensions	mm	5x15	6x18	7x21	10x30	10x30
Dimensions						
A	mm	112	139	174	200	200
B	mm	80	84	108	115	115
C	mm	120	153	160	185	230
D	mm	290	290	410	410	410
E	mm	22	23	30	38	40
F	mm	33	37	45	55	65
H min	mm	300	303	365	485	600
* optional up to 6 m						

TRACTEL S.A.
29, rue du Progrès
F-93108 Montreuil Cedex
Tél. 01.48.58.91.32
Fax 01.48.58.19.95



SECALT S.A.
3, rue du Fort Dumoulin
B.P. 1113 • L-1011 Luxembourg
Tél. (352) 43.42.42-1
Fax (352)43.42.42-200

tralift®

manual chain hoists with accessories



 **Tractel** Group



lightweight chain hoists

Tralift chain hoists are lightweight and compact portable lifting machines for a wide variety of applications: for example,

- ◆ Construction: lifting and positioning of building materials and sections.
- ◆ Garages: removal and replacement of engines.
- ◆ Theatres and concerts: lifting and suspension of scenery and lifting systems.
- ◆ Factories: lifting, handling and positioning of materials and equipment.

Manufactured from high quality materials, fitted with Grade 80 link chain as standard, using a double spur gear mechanism, automatic brake and double pawl system and the option of a load limiting device, TRALIFT chain hoists are robust, reliable and safe.

CE marked (machine Directive 89/392/CEE, amended by 91/368/CEE, 93/44/CEE and 93/68/CEE).

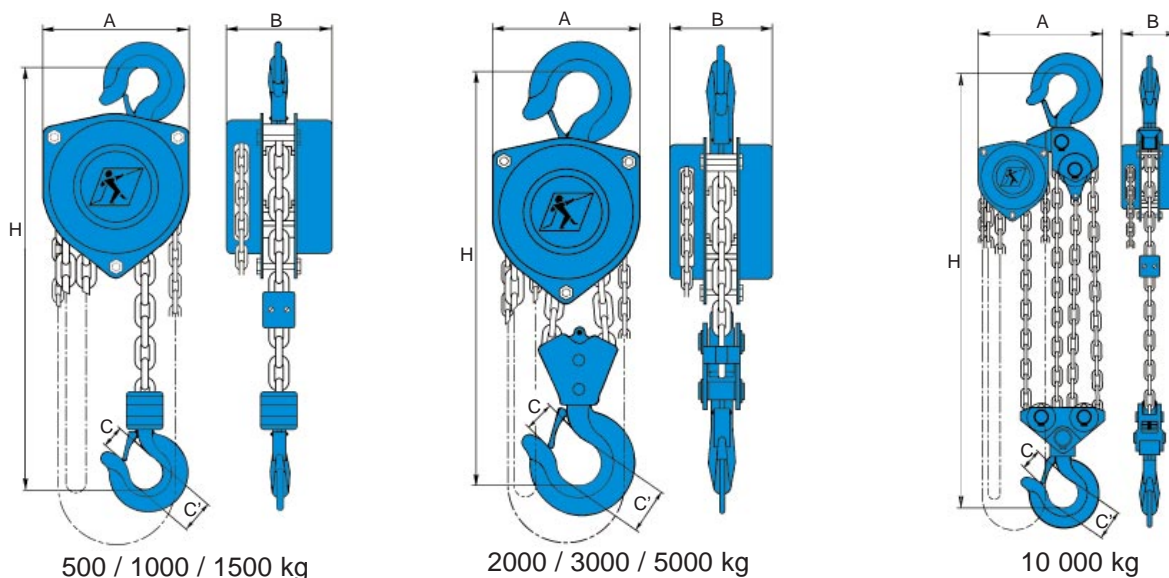

Code*	Lifting Capacity daN/kg	Standard height of lift** m	Number of falls of chain	Effort for WLL daN/kg	Load chain mm	Hand chain mm	Dimensions (mm)					Weight (kg)	
							A	B	C	C'	H min.	machine + chain std. 3m	extra m. of chain**
19709	500	3	1	21	5x15	5x24	132	111	23	26	290	9	1.5
19719	1000	3	1	35	6x18	5x24	156	134	27	30	340	13	1.8
19729	1500	3	1	39	8x24	5x24	196	149	31	34	430	19	2.3
19739	2000	3	2	35	6x18	5x24	156	134	35	38	490	19	2.7
19749	3000	3	2	39	8x24	5x24	196	149	39	42	560	27.5	3.7
19759	5000	3	2	42	10x30	5x24	229	171	45	48	700	43	5.3
19769	10000	3	4	45	10x30	5x24	395	171	57	65	820	78	9.7
19779	20000***	3	8	45	10x30	5x24	642	202	75	85	1050	172	19.4

* Machine complete with chain for standard 3m lift, without load limiter.

** Weight of load chain and hand chain per meter.

*** Model available on special order.

overhead travelling trolleys

The range of CORSO overhead travelling trolleys has been designed for many applications to suspend a variety of lifting equipment.

CE marked (machine Directive 89/392/CEE, amended by 91/368/CEE, 93/44/CEE and 93/68/CEE).

Features :

- ◆ Easily adjustable to fit a wide range of beams.
- ◆ Anti-drop bars ensure safe operation.
- ◆ End stops prevent wheel damage.
- ◆ Locking nuts avoid accidental dismanthng.
- ◆ Wheels with ball bearing for ease of use and smooth operation.
- ◆ Oval anchor point for fast and easy attachment of lifting gear.
- ◆ Unit available with or without chain-operated



Chain-operated geared trolley

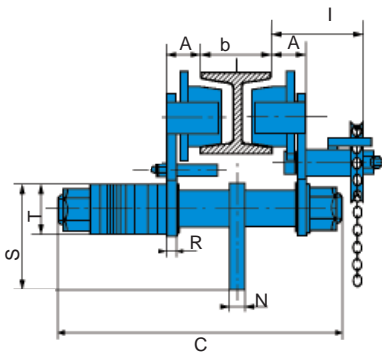

Push trolley

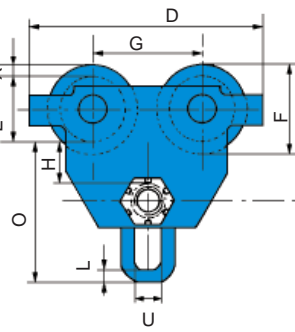

Trolley 20 t with chain-operated geared trolley

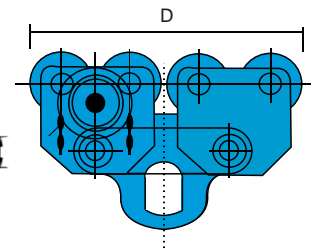
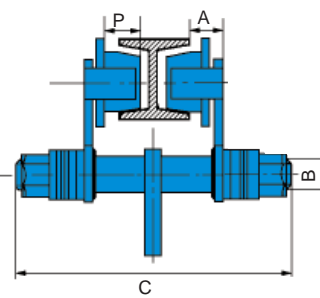

Geared trolleys with chain-operated travel: 1 tonne to 20 tonnes

Code*	Capacity t	Width l of beam* b	Radius of curve m	Effort on chain kg	Lost height (mm) O	Dimensions (mm)															Weight kg	**	
						A	∅ B	C	D	∅ E	∅ F	G	H	∅ T	R	S	L	X	P	N			I
23339	1	60 to 195	1.5	5	150	28	30	320	265	75	102	120	35	50	10	110	17	14	27	12	120	30	14
23349	2	85 to 195	2	9	185	30	35	340	300	90	120	135	35	60	12	145	22	15	33	16,5	105	43	22
23359	3	90 to 195	2.5	14	210	35	42	360	350	110	145	155	45	78	15	170	27	16	35	16	125	46	42
23369	5	110 to 175	2.5	20	250	45	48	375	390	120	155	170	65	78	20	215	35	18	40	20	135	60	61
24829	10	125 to 203	2.5	34	326	52	50	405	470	150	120	200	45	63	25	246	50	15	44	25	170	80	100
24839	20	136 to 203	5.0	68	326	52	50	405	955	150	120	200	45	63	25	246	70	15	44	36	170	110	210

Push trolleys - 0.5 tonne to 20 tonnes

23309	0.5	60 to 165	1	-	120	25	24	255	220	58	82	102	35	44	7.6	90	15	12	27	12	-	25	7.5
23319	1	60 to 195	1.5	-	150	28	30	320	265	75	102	120	35	50	10	110	17	14	27	12	-	30	14
23329	2	85 to 195	2	-	185	30	35	340	300	90	120	135	35	60	12	145	22	15	33	16,5	-	43	22
23379	3	90 to 195	2.5	-	210	35	42	360	350	110	145	155	45	78	15	170	27	16	35	16	-	46	42
23389	5	110 to 175	2.5	-	250	45	48	375	390	120	155	170	65	78	20	215	35	18	40	20	-	60	61
23399	10	125 to 203	2.5	-	326	52	50	405	470	150	120	200	45	63	25	246	50	15	44	25	-	80	100

* Ensure that beam sizes and capacities are compatible with trolley and hoist being used.

** Weight of the machine with 2.5 m of standard 5x24 chain (for a lift of 3m).

beam clamps

Lightweight manually adjustable clamps for a quick and easy method of attachment to overhead «I» beams for a convenient anchor point for our range of TRALIFT and BRAVO hoists, and other types of hoist.
CE marked (machine Directive 89/392/CEE, amended by 91/368/CEE, 93/44/CEE and 93/68/CEE).

Features :

- ◆ 5 models (capacities from 1 to 10 tonnes).
- ◆ Compact and lightweight for easy assembly and dismantling.
- ◆ Heavy duty construction.
- ◆ Adjustable for a wide range of beam widths.

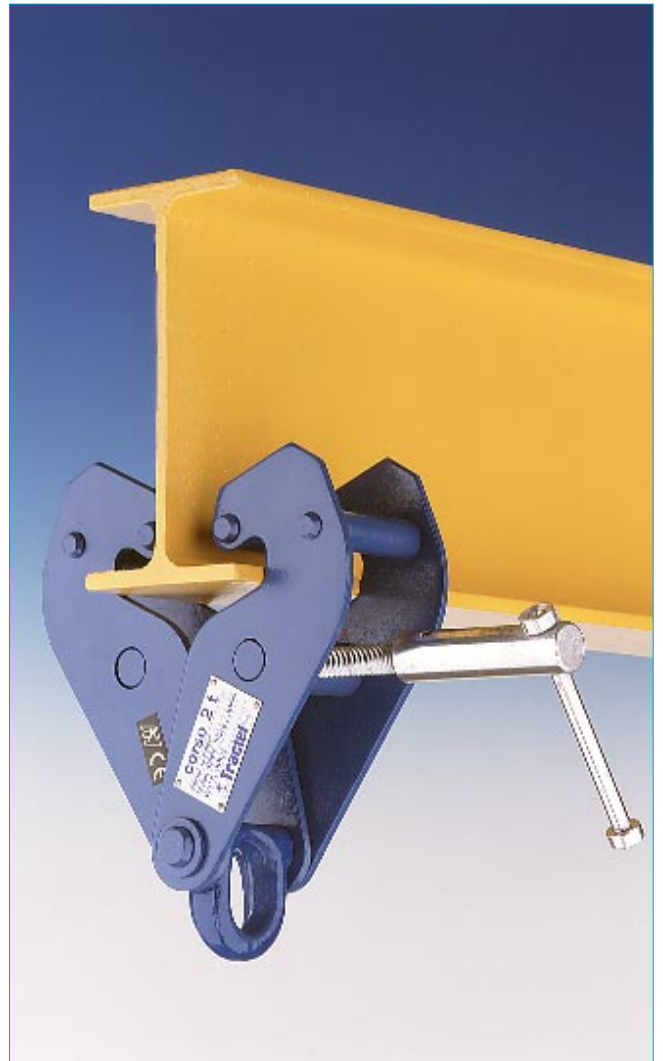
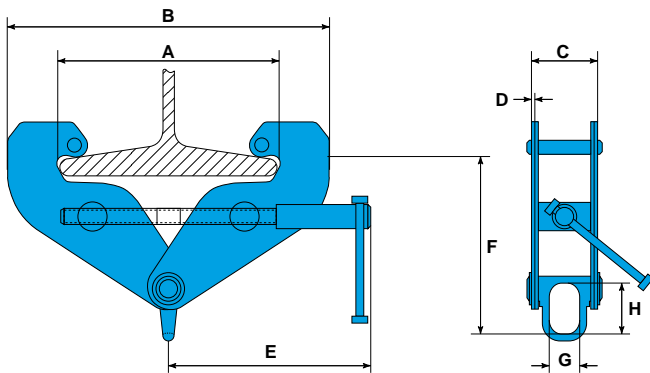

Code	model	Capacity t	Recommended I beam mm	Weight kg	Dimensions (mm)								
					A max.	B min.	B max.	C	D	E	F max.	F min.	G x H
7009	LT - 1B	1	75 to 250	4.5	270	180	380	76	4	210	175	120	30 x 45
7019	LT - 2B	2	75 to 250	4.5	270	182	380	84	6	210	180	130	30 x 40
7029	LT - 3B	3	95 to 360	11	360	235	490	115	8	275	250	175	45 x 60
7039	LT - 5B	5	80 to 320	12.3	354	253	490	138	10	245	220	140	45 x 60
7049	LT - 10B	10	100 to 320	20	320	255	480	160	12	275	300	250	60 x 90

Examples of applications:

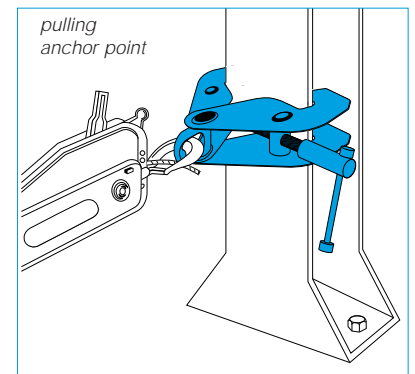
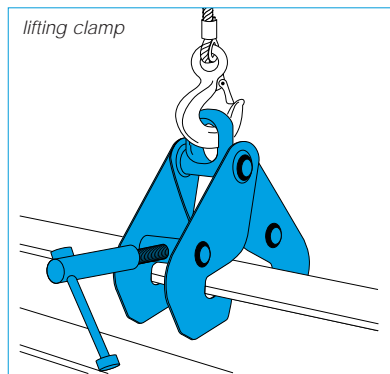
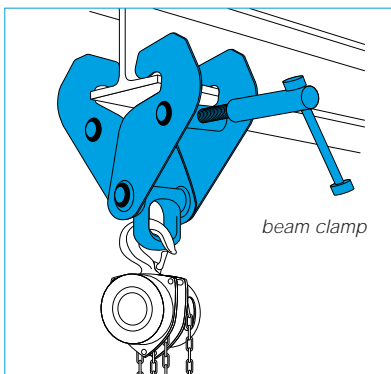

tralift

electric chain hoists

New for 1997
Another TRACTEL Group
Product



CE

TE series
125 to 2000 kg

 **Tractel** Group

tralift TE

A complete range of electric chain hoists

Features :

- Lightweight aluminium casing.
- Minimal lost height below the hook.
- Adjustable upper and lower end limit switches.
- Friction load limiter on all models
- Load chain to DIN 5684, class 8 case hardened.
- Operating factor : 30% to FEM 1 Am, ISO M4, tested to FEM n° 9511, 9755 and 9852.
- IP 55 protection.
- Low voltage controls (48V) : Télémécanique groupe SCHNEIDER electric components and pendant control box.
- CE marked (Machine Directive 89/392/CEE, 91/368/CEE, 93/44/CEE and 93/31/CEE, EMC Directive 89/336/CEE and 92/31/CEE).
- In accordance with standards N° EN 292-1 & -2, EN 418, EN 55014, EN 61000-2-3, EN 61000-3-3.
- Emergency stop on all models by main contactor in accordance with EN 418 category O.

Five capacities from 125 to 2000 kg for many lifting and handling applications.

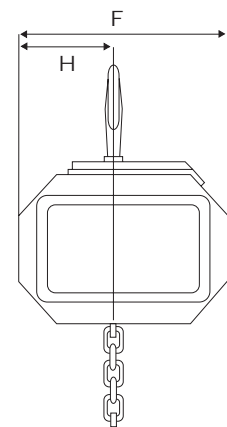
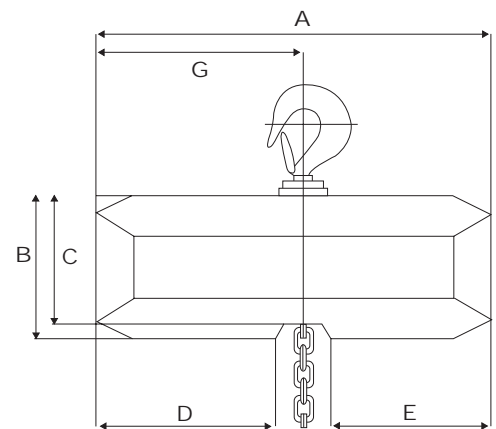

models	Number of falls	Lifting height m	Speed m/min	Motor rating kW	Weight kg	Dimensions					
						A mm	B mm	C mm	D mm	E mm	F mm
TE 125	1	3	10	0,3	18	479	176	128	192	132	200
TE 250	1	3	8	0,5	24	498	190	140	185	132	216
TE 500	1	3	8	0,9	30	521	198	156	185	130	223
TE 500	2	3	4	0,5	31	498	190	140	185	132	216
TE 1000	1	3	6,3	1,5	60	485	185	185	-	-	285
TE 1000	2	3	4	0,9	36	521	198	156	185	130	223
TE 2000	2	3	3,15	1,5	66	485	185	185	-	-	285

P 2034 GB - 2000 - 03/97

TRACTEL S.A.
29, rue du Progrès
F-93108 Montreuil Cedex
Tél. (01) 48 58 91 32
Fax (01) 48 58 19 95



SECALT S.A.
3, rue du Fort Dumoulin
B.P. 1113 • L-1011 Luxembourg
Tél. (352) 43 42 42-1
Fax (352) 43 42 42-200

ratchak[®]

cable and belt hoists



ratchak[®]

light and compact.

This product is ideal for all traction, tension and tightening work over short lengths. The design of RAT-CHAK makes it easy to use and totally safe.

◆ Business area

- Building trade
- Industry
- Agriculture

◆ Ease of use

- use 1 or 2 lines (block and tackle)
- 360° hook rotation
- operating wheel for easy cable winding and unwinding

◆ Safety

- in the event of an overload, the operating lever bends (thus preventing breaks).
- forged hook with safety flap.
- double drum locking system.

◆ Strength

- cast aluminium alloy housing reduces corrosion and weight.
- preformed aircraft standard cable.
- stainless steel springs.

↔ belt version : fiberglass lever.



cable hoist



belt hoist

RATCHAK : cable and belt hoists						single line		double line		lifting lever	
code	model	capacity	length	capacity	length	device	length	weight			
		kg	m	kg	m	mm	m	kg			
24 669	C750-6			750	6		1500	3	cable ø 4.75	0.5	5
24 679	C1000-6			1000	6		2000	3	cable ø 6.35	0.6	6
24 689	S750-3			750	3		1500	1.5	hoist	0.5	4.5

